

Intrinsically Safe Flame Detector Installation Guide

General

This Installation Guide gives information on the intrinsically safe (I.S.) version of the flame detectors that have been approved by BASEEFA (British Approvals Service for Electrical Equipment in Flammable Atmospheres). The requirements of the European Community Directive 94/9/EC, the ATmosphere EXplosives ATEX Directive have been met. The approval has been accessed to European Standards EN 60079-0, EN 60079-11 and EN 60079-26.

The detectors are certified  II 1 G Ga Ex ia IIC T4 and can be used with all listed gases.

The range comprises single infra-red (IR), dual infra-red (IR²) and triple infra-red (IR³) flame detectors. The detector housings are available in zinc metal alloy or stainless steel and also stainless steel (antistatic) glass filled polycarbonate.

The guide also provides information on intrinsic safety, the application, maintenance, installation and adjustments of the detectors. Reference to other individual detector publications can be made for more information on none intrinsically safety issues. These publications are available on request.

Introduction to Intrinsic Safety

There are many places where an explosive mixture of air and gas or vapour is or may be present continuously, intermittently or as a result of an accident. These are defined as hazardous areas by BS EN 60079-0:2006, Electrical apparatus for potentially explosive atmospheres – General requirements.

Hazardous areas are common in petroleum and chemical engineering plants and in factories processing and storing gases, solvents, paints and other volatile substances.

Electrical equipment for use in these areas needs to be designed so that it cannot ignite an explosive mixture, not only in normal operation but also in fault conditions. There are a number of methods available to achieve this – oil immersion, pressurised apparatus and powder filling, for example, but the two most common used are flameproof enclosures and intrinsic safety.

Flameproof equipment is contained in a box so strong that an internal explosion will neither damage the box nor be transmitted outside the box. The surface must remain cool enough not to ignite the explosive mixture.

When flameproof equipment is interconnected, flameproof wiring must be used. This method is most valuable when high power levels are unavoidable but it is not acceptable for areas in which an explosive gas/air mixture may be continuously present or present for long periods.

For this reason these flame detectors are made intrinsically safe rather than flameproof. Intrinsically safe equipment operates at such low power and with such small amounts of stored energy that it is incapable of causing ignition:

- In normal conditions
- With a single fault (for **ib** type of protection code)
- With any combination of two faults (for **ia** type of protection code)

In any of these conditions every component must remain cool enough not to ignite gases for which it is approved. See Table 2

Classification of Hazardous Areas

EN 50014 states that electrical apparatus for potentially explosive atmospheres is divided into:

- Group I: Electrical apparatus for mines susceptible to fire damp;
- Group II: Electrical apparatus for places with a potentially explosive atmosphere, other than mines susceptible to fire damp.

These flame detectors are designed to meet the requirements of Group II apparatus. For the type of protection "i" intrinsically safe, Group II is subdivided into Equipment Categories, Type of Explosive Atmosphere (Table 1), Type of Protection Code (Table 2), Temperature Class (Table 3) and Gas Group (Table 4).

EC Declaration of Conformity

to

Equipment or Protective System Intended for use in Potentially Explosive Atmospheres Directive 94/9/EC

EC-Type Examination Certificate Job Number: **4645**
Equipment or Protective System: **016XXX FLAME SENSOR**
Manufacturer: **Talentum Developments Ltd.
Beal Lane, Shaw,
Oldham,
Lancs.
OL2 8PF, UK**

This equipment or protective system and any acceptable variation thereto is specified in the schedule of documents to this certificate.

The Baseefa Ltd., Rockhead Business Park, Staden Lane, Buxton UK, notified body number 1180 in accordance with Article 9 of the Council Directive 94/9/EC of 23 March 1994, have certified for Talentum Developments Ltd. that this equipment or protective system has been found to comply with the Essential Health and Safety Requirements relating to the design and construction of equipment and protection systems intended for use in potentially explosive atmospheres given in Annex II to the Directive.

Baseefa, EC-Type Examination Certificate Number: **BAS02ATEX1001/1**

Compliance with the Essential Health and Safety Requirements has been assured by compliance with:

EN 60079-0: 2006

EN 60079-11: 2007

EN 60079-26: 2007

The markings of the equipment or protective system shall include the following:-

 **II 1 G Ga Ex ia IIC T4**

Authorised Representative:

J.A. BROADBENT MIET
Director

Date of Issue:

7th November 2008

Talentum File Reference:

WORD\DESIGN\TALENTUM\DES4645\PLAN.DOC

TALENTUM

IS System Drawing with Remote Detector Test Option

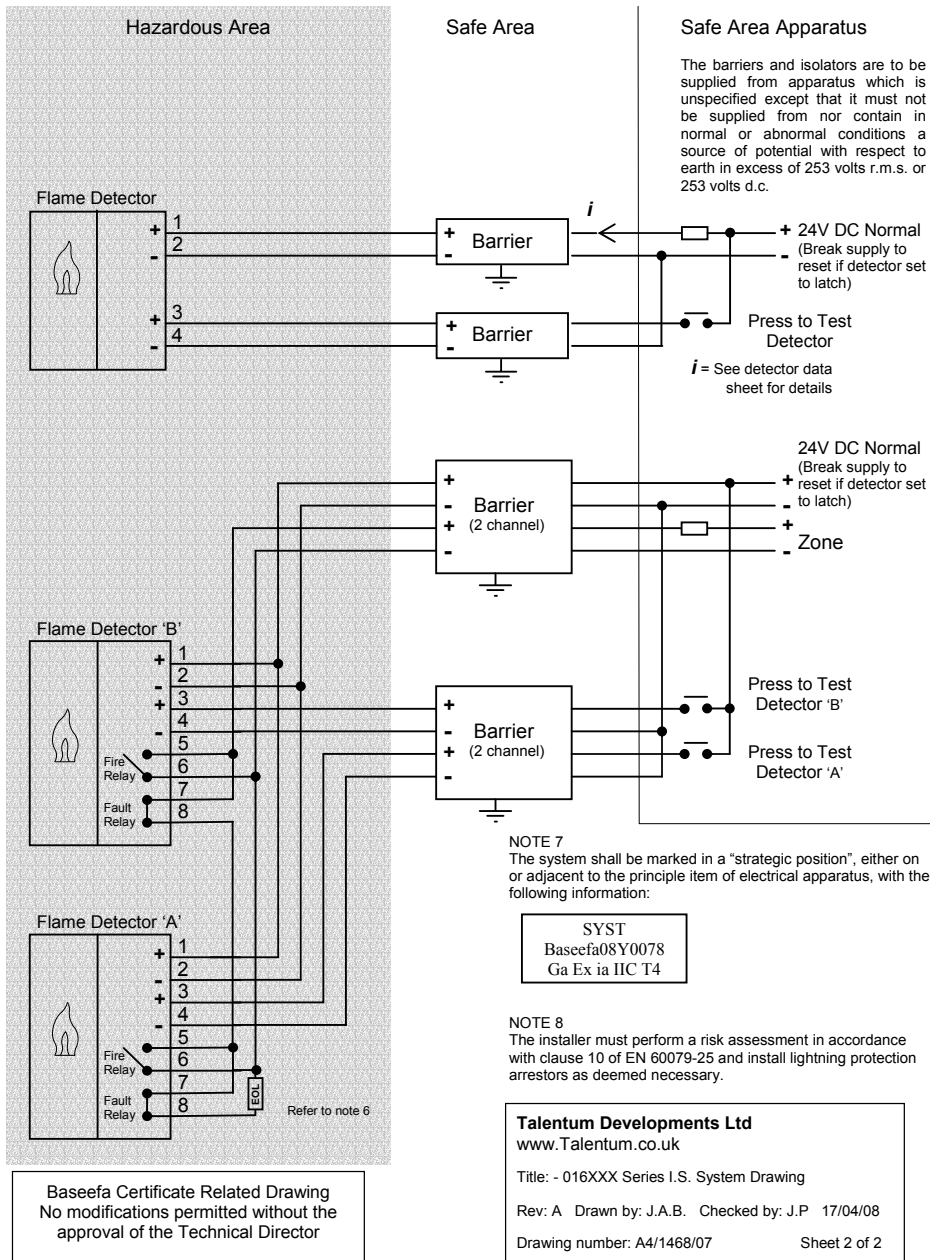

Equipment Markings

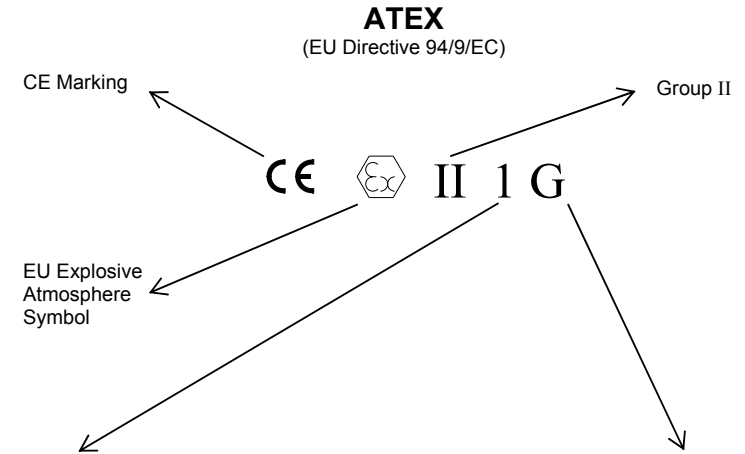

Equipment Category	Definition	Type of Explosive Atmosphere Group II
		Zone
1	- very high level of protection in which explosive atmosphere mixtures of air gases, vapours or mist are present continuously, for long periods	0
2	- high level of protection in which explosive atmosphere mixture of air and gases, vapours or mist are likely to occur	1
3	- normal level of protection in which explosive atmosphere mixtures of air and gases, vapours or mist are unlikely to occur and if it occurs it will exist only for a short period	2
These Flame Detectors are suitable for all the above equipment categories. Note: The detectors are not certified for explosive dust atmospheres.		

Table 1 Equipment Categories and Type of Explosive Atmosphere (Group II)

CENELEC / IEC

Equipment Protection Level (EPL) [See EN60079-26]

Ga Ex ia IIC T4

Explosion Protection symbol

Code	Type of Protection Code	Equipment Category
ia	Intrinsic safety	1
ib	Intrinsic safety	2
d	Flameproof	2

Table 2 Type of Protection Codes

Temperature Class Referred to ambient of -20°C to +40°C	Maximum Surface Temperature
T6	85°C
T5	100°C
T4	135°C
T3	200°C
T2	300°C
T1	450°C

Table 3 Temperature Classification

Gas Group	Representative Gas	Other Gases, Liquids, Vapours
IIC	Hydrogen	Acetylene, Carbon Disulphide
IIB	Ethylene	Diethyl ether, Tetrafluoroethylene
IIA	Methane	Butane, Methanol, Petroleum, Propane, Styrene

These Flame Detectors are approved IIC for listed gases in EN 60079-0.

Table 4 Subdivisions of Group II Gases

IS System Drawing

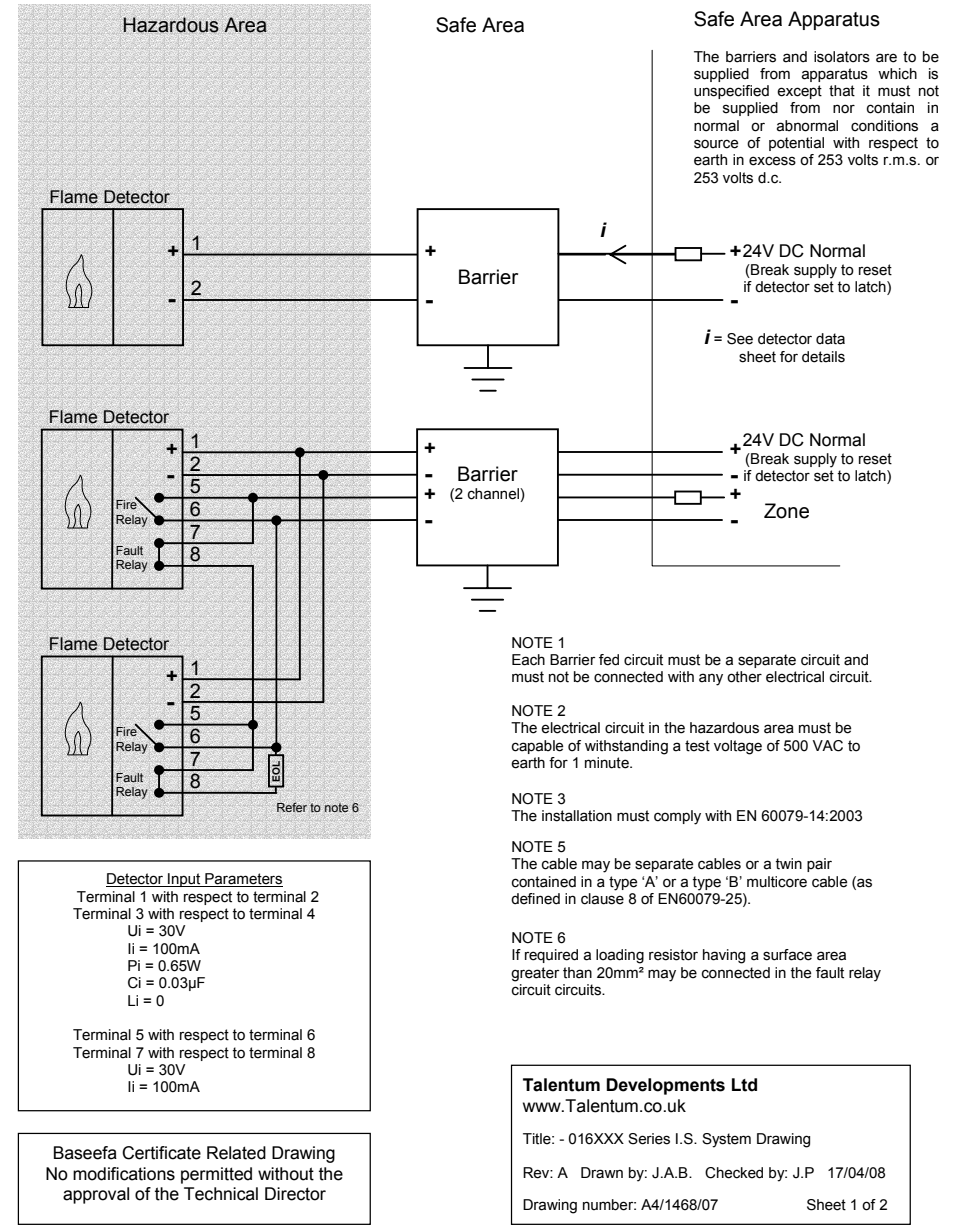

Maximum Loading of IS Circuit

Because of the finite resistance of the safety barrier, there will be a limit to the current drain which can be tolerated before the voltage on the circuit falls outside the specified limits for the IS detector. The standing current for the detectors can be

calculated by the sum of the individual selected detector currents as given in the detector data sheet. This will limit the maximum number of detectors per barrier to two.

Installation

It is important that the IS detectors are installed in such a way that all terminals and connections are protected to at least IP20 with the detector cover fitted. The earth bonding terminals are provided for

convenience where continuity of a cable sheath or similar is required. The installation of the system must be done in accordance with EN 60079-14.

Protection Against Lightning

The installer must perform a risk assessment in accordance with clause 10 of EN 60079-

25 and install lightning protection arrestors as deemed necessary.

Marking

The system shall be marked in a "strategic position", either on or adjacent to the

<p>SYST Baseefa08Y0078 Ga Ex ia IIC T4</p>
--

principle item of electrical apparatus, with the following information:

Service & Repairs

Servicing of IS flame detectors may be carried out only by a BASEEFA or equivalent authorised body. In practical terms this means that IS flame detector may be serviced only at the manufactures factory.

Servicing of the fire protection system should be carried out as recommended by the local regulation in force.

Intrinsically Safe Products

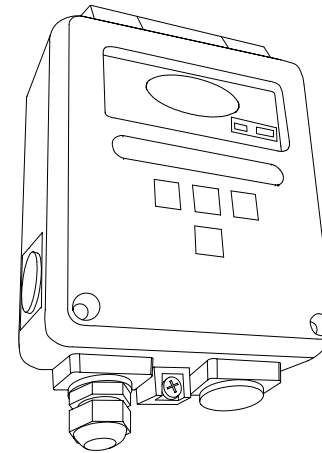

Intrinsically Safe Flame Detector
(Polycarbonate Housing)
Fig. 1

The flame detectors respond to light emitted from flames during combustion.

The detectors discriminate between flames and other light sources by responding only to low frequency flickering produced by flames (typically 1 to 15Hz). The detectors ignore fixed light sources and rapidly flickering illumination predominantly produced by lighting.

The flame flicker techniques have the advantage of still allowing the detection of flames through a thin layer of oil, water vapour, ice or dust. This makes these detectors particularly useful in industrial applications.

Full details of the principles of operation, electrical description, and other detailed technical data are published in the products individual data sheet.

Technical Data

Mechanical

Housing Material: See figure 1	Stainless Steel & Glass Reinforced Polycarbonate
Housing Colour:	Blue (typical)
Housing Dimension: (Excluding Mount)	Height = 148mm Width = 110mm Depth = 63mm
Cable Gland Entries:	4 X 20mm

Electrical

Supply In: Voltage Current Polarity sensitive	Terminals 1(+) & 2(-) 14 to 30Vdc 2 to 30mA See data sheet for detail
Optional Input: Voltage Current Polarity sensitive	Terminals 3(+) & 4(-) 14 to 30Vdc 40µA typ. @ 24V IN
Optional Output: Voltage Current Internally Limited	Terminals 3(+) & 4(-) 0V to Supply In (O/C) 2.4mA typ.
Optional Relays Contact Ratings: Resistive Voltage Loads Only Current	Terminals 3 to 8 30Vdc. Max. 1 Amp. Max.

Environmental

Operating Ambient Temperature: Check detector limits	-20°C to +40°C(T4)
ATEX Approval Category	II 1 G
CENELEC / IEC Marking	Ga Ex ia IIC T4
Apparatus Certificate Number	BAS02ATEX1001
System Certificate Number	Baseefa08Y0078

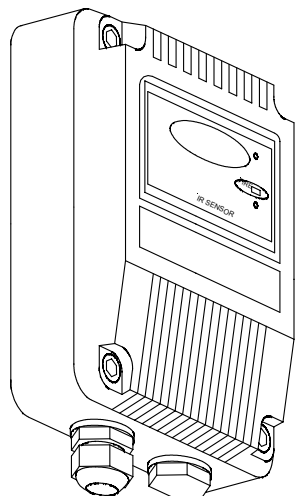

Intrinsically Safe Flame Detector
(Alloy Housing)
Fig. 2

The flame detectors respond to light emitted from flames during combustion.

The detectors discriminate between flames and other light sources by responding only to low frequency flickering produced by flames (typically 1 to 15Hz). The detectors ignore fixed light sources and rapidly flickering illumination predominantly produced by lighting.

The flame flicker techniques have the advantage of still allowing the detection of flames through a thin layer of oil, water vapour, ice or dust. This makes these detectors particularly useful in industrial applications.

Full details of the principles of operation, electrical description, and other detailed technical data are published in the products individual data sheet.

Technical Data

Mechanical

Housing Material: See figure 2	Die Cast Zinc Alloy
Housing Colour:	Blue (typical)
Housing Dimension: (Excluding Mounts)	Height = 142mm Width = 108mm Depth = 82mm
Cable Gland Entries:	2 X 20mm

Electrical

Supply In: Voltage Current Polarity sensitive	Terminals 1(+) & 2(-) 14 to 30Vdc 2 to 30mA See data sheet for detail
Optional Input: Voltage Current Polarity sensitive	Terminals 3(+) & 4(-) 14 to 30Vdc 40µA typ. @ 24V IN
Optional Output: Voltage Current Internally Limited	Terminals 3(+) & 4(-) 0V to Supply In (O/C) 2.4mA typ.
Optional Relays Contact Ratings: Resistive Voltage Loads Only Current	Terminals 3 to 8 30Vdc. Max. 1 Amp. Max.

Environmental

Operating Ambient Temperature: Check detector limits	-20°C to +40°C(T4)
ATEX Approval Category	II 1 G
CENELEC / IEC Marking	Ga Ex ia IIC T4
Apparatus Certificate Number	BAS02ATEX1001
System Certificate Number	Baseefa08Y0078

Cables

The interconnections to any of the four intrinsically safe circuit configurations shown on the system drawings may be achieved by separate cables or by separate circuits within a Type A or Type B multicore cable (clause 8 of EN 60079-25) subject to the following:

- Each circuit is to be individually screened within a Type A multicore cable.
- The peak voltage of any circuit within a Type B multicore cable must not exceed 60V, and the cable must be effectively protected against damage.

Only insulated cables meeting the requirements of clause 8 of EN 60079-25 shall be used.

The installation of the system must be done in accordance with EN 60079-14.

Maximum Cable Lengths

The following cable types are considered to be Type B cables suitable for use in the Flame Detector system. The maximum permitted cable lengths when using these cables is shown below:

Cable Type	Core	Maximum Cable Length		
		IIC	IIB	IIA
AEI Cables 6193Y (BS6004)	3	379m (620m)	5.00km(5.00km)	5.00km(5.00km)
Prysmian FP200Gold 1.5mm ² (Formally Pirelli)	2 or 4	313m (513m)	5.00km(5.00km)	5.00km(5.00km)
AEI Cables M.I. ref 7H1.5	7	213m (350m)	3.45km(3.59km)	5.00km(5.00km)
AEI Cables M.I. ref 2L1.5	2	146m (240m)	2.37km(2.46km)	5.00km(5.00km)

Table 8 Examples of maximum permissible cable lengths – [Two detectors (Single detector)]

When only a single Flame Detector Power Supply terminal pair (terminals 1 & 2) or Remote Test terminal pair (terminals 3 & 4) is connected to a single circuit from the barrier or isolator listed in table 5 then the capacitance may be increased to the values shown in brackets. The increase in cable capacitance is not affected by the number of Flame Detectors Fire Relay connect terminal pairs (terminals 5 & 6) or Fault Relay contact terminal pairs (terminals 7 & 8) connected to a single circuit.

Interconnecting Cable Parameters

It is not permitted to connect more than one barrier circuit in the hazardous area to any other circuit.

There are four different intrinsically safe circuits shown on the system drawings. The stated cable parameters are based on each Power Supply circuit, Remote Test circuit and Relay Output circuit being isolated from each other with no other apparatus (other than the optional resistor across the Relay Output circuit) being connected.

For each set of parameters shown below the cable capacitance and either the cable inductance or the cable inductance to resistance ratio (L/R) must not exceed the values shown in table 7. The reason for this is that energy can be stored in a cable and it is necessary to use cable in which energy stored is insufficient to ignite an explosive atmosphere.

Cable Parameters

When two Flame Detector Power Supply terminal pairs (terminal 1 & 2) or Remote terminal pairs (terminals 3 & 4) are connected to a single circuit from the barriers or isolators listed in table 5 the permitted cable parameters are as shown in table 7.

Group	Capacitance - μF	Inductance - mH	L/R Ratio - $\mu\text{H}/\text{ohm}$
IIC	0.023 μF (0.053 μF)	4.2mH	54 $\mu\Omega$
IIB	0.59 μF (0.62 μF)	12.6mH	217 $\mu\Omega$
IIA	2.09 μF (2.12 μF)	33.6mH	435 $\mu\Omega$

Table 7 Maximum Permissible Stored Energy in Cables – [Two detectors (Single detector)]

When only a single Flame Detector Power Supply terminal pair (terminals 1 & 2) or Remote Test terminal pair (terminals 3 & 4) is connected to a single circuit from the barrier or isolator listed in table 5 then the capacitance may be increased to the values shown in brackets. The increase in cable capacitance is not affected by the number of Flame Detectors Fire Relay connect terminal pairs (terminals 5 & 6) or Fault Relay contact terminal pairs (terminals 7 & 8) connected to a single circuit.

The above cable parameters are also valid for any non-isolating zener barriers with terminal parameters not exceeding:-

$$U_0 = 28\text{V} \quad I_0 = 93\text{mA} \quad P_0 = 650\text{mW}$$

Note: The flame detectors have zero equivalent inductance ($L_i = 0$) and a 0.03 μF capacitance ($C_i = 0.03\mu$).

System Design

Engineers familiar with codes of practice for hazardous area systems should only undertake the design of an intrinsically safe fire detection system. In Europe the standard is EN 60079-0, Electrical apparatus for potentially explosive atmospheres – General requirements.

The fire detector performance is the same as the standard none intrinsically safe counterparts. Performance information given in standard product guides is therefore applicable to the intrinsically safe range.

The BASEEFA certification of the intrinsically safe devices covers their characteristics as components of an intrinsically safe system. This indicates that the flame detectors can be used with a margin of safety in such systems.

In safe area (standard) applications it is some times desirable to connect the wiring as a loop, with both ends terminated at the control panel. In the event of an open-circuit fault it is then possible to drive both ends simultaneously. In a hazardous area it is not possible to use a loop configuration because the potential to feed power from each end of the loop would double the available energy in the hazardous area and contravene the energy limitations of the intrinsically safe certification. All circuits must therefore be connected as spurs from the safe area or as radial connections from the control panel.

The 016XXX series of Intrinsically Safe Flame Detectors (Sensors) has been assessed as an Intrinsically Safe System by Baseefa as defined in EN 60079-25 for Category ia, Group IIC and Temperature Class T4. See system certificate number Baseefa08Y0078.

Types of Safety Barrier

The system configuration can be for three types of safety barrier, each of which has its own advantages and disadvantages. A brief outline of the characteristics is given below.

28V/300 Ω Barrier

This is the most basic type of barrier and therefore the lowest cost. Being passive devices, they also impose the minimum of restrictions on the operation of the flame detectors. Thus, single channel barriers are available either as positive or negative polarity where the polarity refers to the polarity of the applied voltage *relative to earth*. *The significance of this is that one side of the barrier must be connected to a high-integrity (safety) earth*. Although this connection has no effect on the operation of the flame detector and is not needed for their correct operation, it may not be acceptable to the operation of the control and indicating equipment. This is particularly true if the control equipment incorporates earth-leakage monitoring and even without this feature the earthing of the loop may cause unwanted cross-talk between loops.

If the earth connection is not acceptable then the A.C. or isolating barriers should be used.

Star-connected A.C. Barrier

A.C. barriers are also passive devices and must still be connected to a high-integrity safety earth. However, they are designed to allow either positive or negative voltages with respect to earth and under normal conditions provide a connection to earth via a reverse-diode, rather than directly.

The disadvantage of this type of barrier is that the end-to-end resistance is nominally 1200ohms compared with the 300 ohms of the single channel type. This high resistance results in an extra voltage drop in the circuit. This type of barrier is not recommended for general use.

Galvanically Isolated Barrier

Galvanically isolated barriers (also known as transformer isolated barriers) differ from conventional shunt zener barriers in that they provide electrical isolation between the input (safe area) and the output (hazardous area). This is achieved by the use of a D.C./D.C. converter on the input side, which is connected to the hazardous area through a voltage and power limiting resistor/zener combination similar to a conventional barrier.

The galvanic isolation technique means that the circuit does not need a high integrity (safety) earth and that the intrinsically safe circuit is fully floating. Earth leakage problems for control and indicating equipment are therefore eliminated if this type of interface is used. Galvanically isolated barriers are widely used with conventional flame detector

systems. If the system is of an addressable type with signal pulses on the supply lines then the response time of most standard barriers will be too slow to allow their use. In these applications special galvanically isolated barriers are required that can freely transmit the required protocol pulses without introducing severe voltage drops. These interfaces are available as single or dual channel versions and are recommended for any application in which direct earth connections are not acceptable.

The galvanically isolated barrier is a two-wire device which does not need an external power supply. Current drawn from the detector supply connections by the barrier itself is less than 500µA.

Approved Safety Barriers

For systems a generic specification for the barriers is as follows.

Any non-isolating zener safety barrier certified and approved to meet the ATEX Directives or CENELEC / IEC standards.

ATEX group and category  II (1) G

CENELEC / IEC marking [Ga Ex ia] II C
(associated apparatus)

Having the following or lower output parameters.

Max. output volts U_o : = 28V
Max. output current I_o : = 93mA
Max. output power P_o : = 0.65W

A number of barriers meet this specification and examples are given below.

Supplier	Type	Channels	Technique	Certificate
Pepperl & Fuchs Ltd. 77 Ripponden Road, Oldham, Lancs. OL2 8PF UK www.pepperl-fuchs.com	Z728	1	300Ω Barrier	BAS01ATEX7005
	Z779	2	300Ω Barrier	BAS01ATEX7005
	KFD0-CS-Ex1.51	1	Isolator	BAS98ATEX7343
	KFD0-CS-Ex2.51	2	Isolator	BAS98ATEX7343
MTL Power Court, Luton, Bedfordshire LU1 3JJ UK www.mtl-inst.com	MTL7028+	1	300Ω Barrier	BAS99ATEX7285
	MTL7728+	1	300Ω Barrier	BAS01ATEX7217
	MTL7779+	2	300Ω Barrier	BAS01ATEX7217
	MTL7706+	1	Active 300Ω 4-20mA O/P	BAS01ATEX7217

Table 5 Examples of permitted safety barriers/isolators

The terminal parameters for the isolators and barriers permitted by the system certificate are: -

Type	U_o	I_o	P_o
Z728	28V	93mA	650mW
Z779	28V	93mA	650mW
KFD0-CS-Ex1.51	25.2V	93mA	585mW
KFD0-CS-Ex2.51	25.2V	93mA	585mW
MTL7028+	28V	93mA	650mW
MTL7728+	28V	93mA	650mW
MTL7779+	28V	93mA	650mW
MTL7706+	28V	93mA	650mW

Table 6 Permitted isolator and barrier terminal parameters.

The above barriers and isolators are to be supplied from apparatus which is unspecified except that it must not be supplied from nor contain in normal or abnormal conditions a source of potential with respect to earth in excess of 253 volts r.m.s. or 253 volts d.c.

Safety Earth

Single channel and star connected A.C. safety barriers must be connected to a high integrity earth by at least one and preferably two copper cables, each of cross sectional area of 4mm² or greater. The connection must be such that the impedance from the connection point to the main power system earth is less than one ohm. Intrinsically safe circuits in the hazardous area should be insulated from earth and

must be capable of withstanding a 500V RMS A.C. test voltage for at least one minute.

When using armoured or copper sheathed cables, the armour or sheath is normally isolated from the safe area busbar.

Apparatus Located in the Hazardous Area

The following may be located in the hazardous area: -

- One or two 016XXX Flame Detectors to certificate BAS02ATEX1001 and coded Ga Ex ia IIC T4.
- An optional single resistor that has a surface area of greater than 20mm² may be connected in the fault relay circuit.