

Technical Data – IR² Flame Sensor

Mechanical

Housing Material:	Die Cast Zinc Alloy
Housing Colour:	Blue
Dimensions:	See Fig. 8
Weight:	2.4kg
Cable Gland Entries:	2 x 20mm

Electrical

Sensor Supply:	Voltage	14 to 30Vdc
Terminals 1 & 2	Current	See DIL switch settings
Test Signal Voltage:		14 to 30Vdc
Power Up Time:		2 seconds max.
Relay Contact Ratings:		
RL1 Terminal 5 & 6	Current	0.25Amp. Max.
RL2 Terminal 7 & 8	Voltage	30Vdc. Max.
Resistive Loads Only	Power	3.0W Max.
Sensor Input Parameters:		
Terminal 1 with respect to 2	Ui	30V
Terminal 3 with respect to 4	li	100mA
	Pi	0.65W
	Ci	0.03µF
	Li	0
Terminal 5 with respect to 6	Ui	30V
Terminal 7 with respect to 8	li	100mA

Performance

Range:	- Class 1	0.1m ² n-heptane at 25m 0.2m ² n-heptane at 35m 0.4m ² n-heptane at 45m
(See EN54-10)	- Class 3	0.1m ² n-heptane at 12m
Sensitivity Setting		
Field of View:		90° min. Cone
Spectral Response:	IR	1.0 to 2.7µm
Sensitivity:		High = Class 1 Low = Class 2
(See EN54-10)		

Environmental

BASEEFA Apparatus Certificate No:	BAS02ATEX1001
ATEX Approval Category	II 1 G - Category 1, 2 or 3
CENELEC / IEC Marking	EEx ia IIC T4 - Zone 0, 1 or 2
Operating Temperature:	- 10°C to +40°C (T4) - 10°C to +55°C Sensor Limit
Storage Temperature:	- 20°C to +65°C
Relative Humidity:	95% Non condensing
IP Rating:	IP65
EMC Immunity:	EN 50081-1, EN 50081-2 EN 50082-2, EN 50082-2 EN 50130-4, EN 55022

See Intrinsically Safe Flame Detector Installation Guide for more detail.

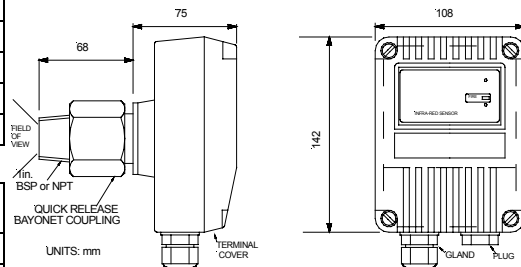

Fig. 8 Dimensions – IR² Flame Sensor
(Gland not supplied)

Selectable Options	DIL Switch Settings	
Relay RL2 Function:	1	2
RL2 Off	0	0
RL2 On	1	0
IR fire or pre-alarm	0	1
Fault (Energised if OK)	1	~ 1
Quiescent & Alarm Currents:	3	4
3/9mA RL1 Only, 4/8/14mA RL2 & RL1	0	0
4-20mA, 4/20mA, No Relays	1	0
/ Or 8-20mA, 8/20mA, & Relays	0	1
- Proportional 8/28mA, & Relays	1	~ 1
Output Mode:	5	
Non-latching (-)	0	
Latching (/)	~1	
Response Time:	6	7
Slowest ≈ 8s	0	0
Medium ≈ 4s	1	~ 0
Fast ≈ 2s	0	1
Very Fast ≈ 1s	1	1
Sensitivity:	8	
Low (Class 3)	0	
High (Class 1)	~ 1	

Factory settings ~

Bayonet Mount 1" BSP/NPT – Supplied separately

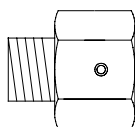

Fig. 9 Bayonet Mounting Part number: 012290

- BS EN 54-10:2002 Fire detector and fire alarm systems; Part 10: Flame detectors – point detectors.
- Although this sensor is not affected by normal daylight conditions, sunlight should be prevented from falling directly on to the IR optics.

016577 INTRINSICALLY SAFE (IS) IR² FLAME SENSOR 012290 BAYONET MOUNT 1" BSP/NPT MALE IN PLATED STEEL

Features

- ATEX certified: II 1 G
- CENELEC/IEC certified: EEx ia IIC T4
- Class 1 Sensitivity to EN54-10
Detects 0.1m² fire @ 25m
- High Optical Interference Immunity
- Selectable Output Options
Conventional 2 wire
4-20mA
Latching or Non-latching
Relay Contacts;
Fire/Fault, Pre-alarm
- Selectable Response Speed
- Optical Self Test
- Low Power Consumption
- CE Marked

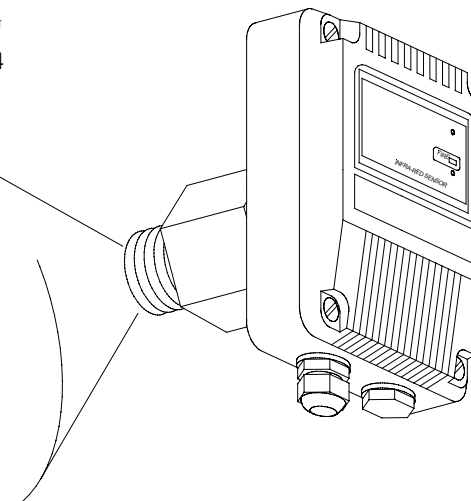

Operating Principles

The sensor responds to low-frequency (1 to 15 Hz) flickering IR radiation emitted from flames during combustion.

IR flame flicker techniques enable the sensor to operate through a layer of oil, dust, water vapour, or ice.

Most IR flame sensors respond to 4.3µm light, emitted by hydrocarbon flames. By responding to 1.0 to 2.7µm light emitted by every fire all flickering flames can be detected. Gas fires not visible to the naked eye e.g. hydrogen may also be detected.

The dual IR photoelectric detectors (IR²), responding to neighbouring IR wavelengths, enable it to discriminate between flames and spurious sources of IR radiation.

The combination of filters and signal processing allows the sensor to be used with a very low risk of false alarms in difficult situations characterised by factors such as flickering sunlight.

Electrical Connections

The sensor can be connected to a two-wire circuit supplying 14V to 30V dc. The sensor is connected to the supply via terminals 1(+IN) and 2(-IN) under the front terminal cover. Connections to the sensor are polarity sensitive.

A remote sensor optical test input is available on terminals 3(+R) for +IN and 4(-R) 0V. When a 14V to 30V dc supply is applied to this input IR test sources activate within the sensor and a flame-detected state will be outputted. See Fig. 1

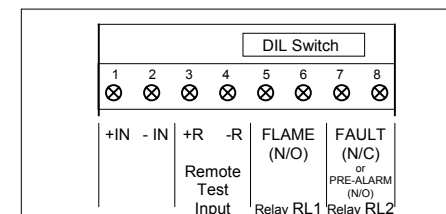

Fig. 1 Connection Terminals (Front Cover Removed)

Flame Detection Characteristics

The sensor responds to varying sizes of flame at given distances. The further away the flame is from the sensor the larger the fire has to be, with detection beyond 50m becoming unpredictable. An n-heptane flame with a base area of 0.1m² will be detected on the sensor centre line at 25m, with the sensitivity set high for class 1 performance. See Fig. 2

If the sensitivity switch were set to low, for class 3 performance, the same 0.1m² flame would be detected at 12m.

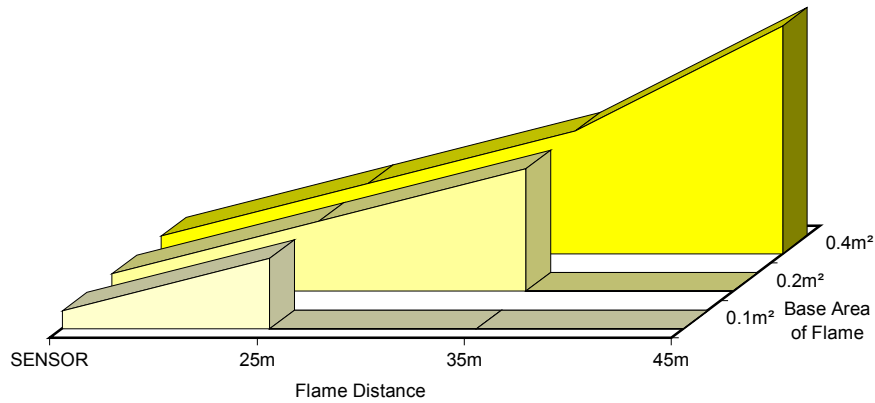

Fig. 2 Sensor centre line detection range for n-heptane fire (yellow sooty flame - IR² Flame Sensor, sensitivity set high for class 1 performance

The polar diagram shows that the sensor sensitivity is at its greatest along the central axis. The variation in relative range against viewing angle is shown as a percentage of peak performance. The diagram is a section through the sensor's conical field of view. See Fig. 3

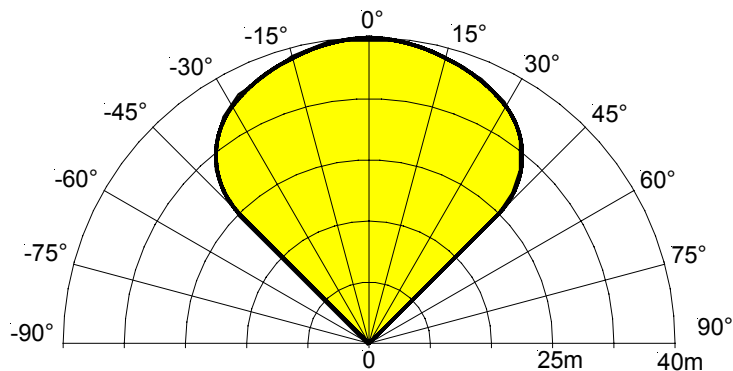

Fig. 3 Relative range as a function of viewing angle - IR² Flame Sensor

Alarm Current Output Values (Latching)

When the sensor detects a flame the sensor supply current value (4-20mA or 8-28mA) will increase.

The sensor is shipped with the internal DIL switch (5) set to give a latching alarm current. Normally the current required by the sensor is 4mA or 8mA at 24Vdc with no flame in view. When a flame is in view, the supply current value will increase to 20mA or 28mA, the fire relay RL1 will energise and red fire LED will illuminate.

The supply to the sensor has to be broken in order to reset the sensor.

Values below 3.0mA are an indication of a fault conditions. See Fig. 4

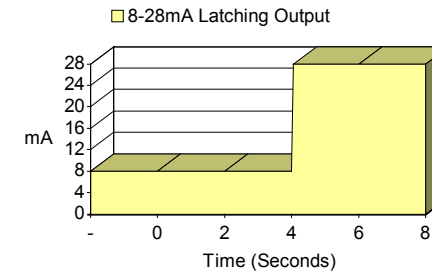

Fig. 4 Typical Response on seeing Flame - IR² Flame Sensor

Once illuminated the red Fire LED and output value are held for 5 seconds after the last flame has been seen, after which the output value decrements back to 4 or 8mA. See Fig. 6

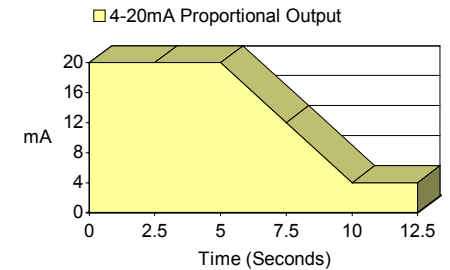

Fig. 6 Typical Response after last Flame seen - IR² Flame Sensor

Proportional Output Values (Non-latching)

When the sensor sees any flame flicker the proportional values of (4-20mA or 8-20mA) will increase.

The sensor is set to give a proportional value of 4mA or 8mA with no flame in view. The value increments when flame flicker pulses are seen.

With an output value approaching 20mA the fire LED will illuminate.

Values below 3.0mA are an indication of a fault conditions. See Fig. 5

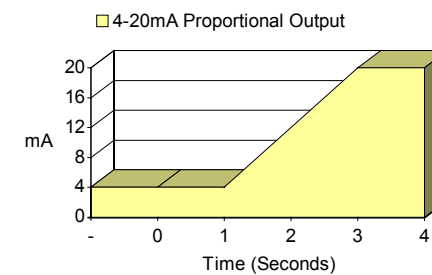

Fig. 5 Typical Response on seeing Flame - IR² Flame Sensor

Proportional output values between 4 or 8mA and 20mA can be used to provide an early warning of fire. These values hold only for 3 seconds from the last flame sighting. See Fig. 7

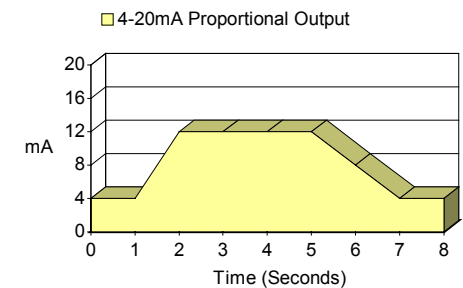

Fig. 7 Typical Response to Burst of Flame - IR² Flame Sensor