

## Technical Data – IR Flame Sensor

### Mechanical

Housing Material:	Stainless Steel & Glass Reinforced Polycarbonate
Housing Colour:	Blue
Dimensions:	See Fig. 9
Weight:	1kg
Cable Gland Entries:	4 x 20mm

### Electrical

Supply Voltage:	14 to 30Vdc
Supply Current:	See DIL switch settings
Power Up Time:	2 seconds max.
Test Signal Voltage:	14 to 30Vdc
Relay Contact Ratings:	
Current	1.0Amp. Max.
Voltage	50Vdc. Max.
Resistive Loads Only Power	30W Max.

### Performance

Range:	- Class 1	0.1m <sup>2</sup> n-heptane at 25m 0.2m <sup>2</sup> n-heptane at 35m 0.4m <sup>2</sup> n-heptane at 45m
Sensitivity Setting	- Class 3	0.1m <sup>2</sup> n-heptane at 12m
Field of View:		90° min. Cone
Spectral Response:	IR	0.75 to 2.7µm
Sensitivity:	(See EN54-10)	High = Class 1 Low = Class 3

### Environmental

Operating Temperature:	- 10°C to +55°C
Storage Temperature:	- 20°C to +65°C
Relative Humidity:	95% Non condensing
IP Rating:	IP65
EMC Immunity / Emissions:	EN61000-6-1, EN61000-6-2 EN61000-6-3, EN61000-6-4 EN 50130-4, EN 55022

### DIN Rail Mounting Options

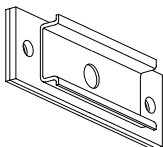
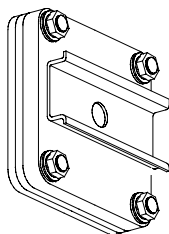

Fig. 8 Duct Mount  
P/N 012562



Flange Mount  
P/N 012566

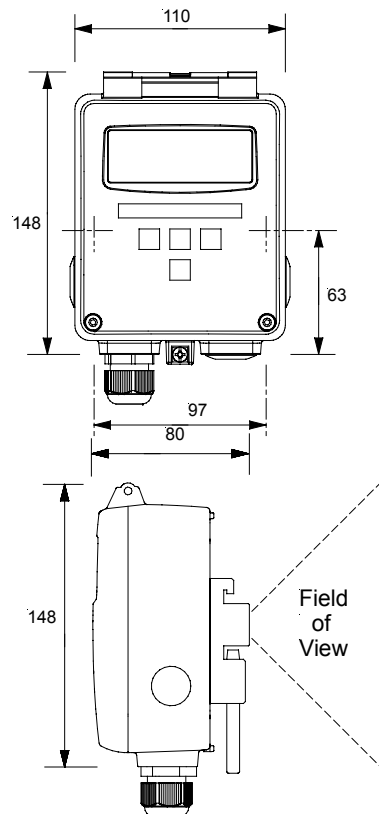

Fig. 9 Dimensions – IR Flame Sensor

Selectable Options	DIL Switch Settings	
Relay RL2 Function:	1	2
RL2 Off	0	0
RL2 Off	1	0
IR fire or pre-alarm	0	1
Fault (Energised if OK)	1	~ 1
Alarm Current: [RL1 Flame Relay]	3	4
3/9mA RL1 Only, 4/8/14mA RL2 & RL1	0	0
4-20mA, 4/20mA, No Relays	1	0
/ Or 8-20mA, 8/20mA, & Relays	0	1
- Proportional 8/28mA, & Relays	1	~ 1
Output Mode:	5	
Non-latching (-)	0	
Latching (/)	~1	
Flicker Counts: Pre-alarm (RL2), Flame (RL1)	6	7
Slowest 4 10	0	0
Medium 3 8	1	~ 0
Fast 2 6	0	1
Very Fast 1 4	1	1
Sensitivity:	8	
Low (Class 3)	0	
High (Class 1)	~ 1	

Factory settings ~

Data Sheet

## 016502 IR FLAME SENSOR for DIN Rail Mounting

### Features

- Class 1 Sensitivity to EN54-10  
Detects 0.1m<sup>2</sup> fire @ 25m
- Selectable Output Options  
Conventional 2 wire  
4-20mA  
Latching or Non-latching  
Relay Contacts;  
Fire/Fault, Pre-alarm
- Selectable Response Speed
- Optical Self Test
- Low Power Consumption
- CE Marked

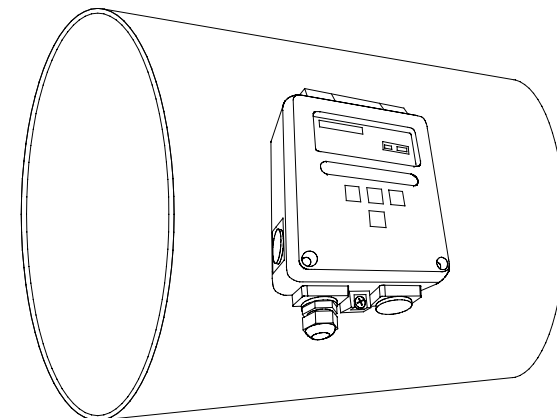

### Operating Principles

The sensor responds to low-frequency (1 to 15 Hz) flickering IR radiation emitted from flames during combustion.

IR flame flicker techniques enable the sensor to operate through a layer of oil, dust, water vapour, or ice.

Most IR flame sensors respond to 4.3µm light, emitted by hydrocarbon flames. By responding to 1.0 to 2.7µm IR emissions from combusting material almost all flickering flames and embers can be detected. Gas fires not visible to the naked eye e.g. hydrogen may also be detected.

The combination of filters and signal processing allows the sensor to be used with a low risk of false alarms while looking in dark machinery and ductwork. Avoid locating the sensor in application where light can fall on the IR photocell.

### Electrical Connections

The sensor can be connected to a two-wire circuit supplying 14V to 30V dc. The sensor is connected to the supply via terminals 1(+IN) and 2(-IN) under the front terminal cover. Connections to the sensor are polarity sensitive.

A remote sensor optical test input is available on terminals 3(+R) for +IN and 4(-R) 0V. When a 14V to 30V dc supply is applied to this input IR test sources activate within the sensor and a flame-detected state will be outputted. See Fig. 1

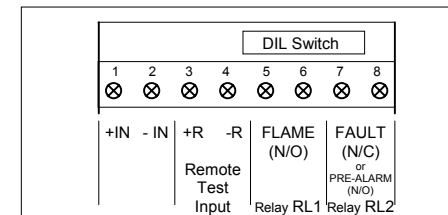

Fig. 1 Connection Terminals (Front Cover Removed)

1. BS EN 54-10:2002 Fire detector and fire alarm systems; Part 10: Flame detectors – point detectors.

## Flame Detection Characteristics

The sensor responds to varying sizes of flame at given distances. The further away the flame is from the sensor the larger the fire has to be, with detection beyond 50m becoming unpredictable. An n-heptane flame with a base area of 0.1m<sup>2</sup> will be detected on the sensor centre line at 25m, with the sensitivity set high for class 1 performance. See Fig. 2

If the sensitivity switch were set to low, for class 3 performance, the same 0.1m<sup>2</sup> flame would be detected at 12m.

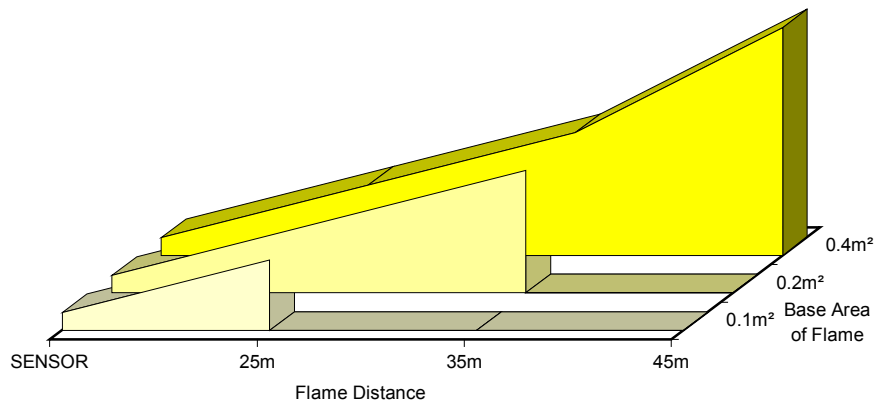

**Fig. 2** Sensor centre line detection range for n-heptane fire (yellow sooty flame - IR Flame Sensor, sensitivity set high for class 1 performance)

The polar diagram shows that the sensor sensitivity is at its greatest along the central axis. The variation in relative range against viewing angle is shown as a percentage of peak performance. The diagram is a section through the sensor's conical field of view. See Fig. 3

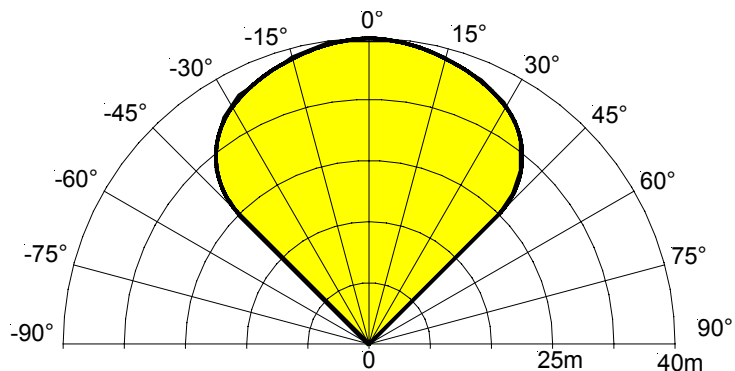

**Fig. 3** Relative range as a function of viewing angle - IR Flame Sensor

## Alarm Current Output Values (Latching)

When the sensor detects a flame the sensor supply current value (4-20mA or 8-28mA) will increase.

The sensor is shipped with the internal DIL switch (5) set to give a latching alarm current. Normally the current required by the sensor is 4mA or 8mA at 24Vdc with no flame in view. When a flame is in view, the supply current value will increase to 20mA or 28mA, the fire relay RL1 will energise and red fire LED will illuminate.

The supply to the sensor has to be broken in order to reset the sensor.

Values below 3.0mA are an indication of a fault condition. See Fig. 4

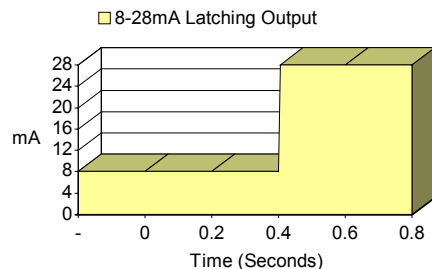

**Fig. 4** Typical Response on seeing Flame - IR Flame Sensor

Once illuminated the red Fire LED and output value are held for 5 seconds after the last flame has been seen, after which the output value decrements back to 4 or 8mA. See Fig. 6

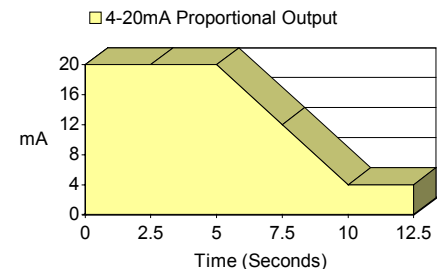

**Fig. 6** Typical Response after last Flame seen - IR Flame Sensor

## Proportional Output Values (Non-latching)

When the sensor sees any flame flicker the proportional values of (4-20mA or 8-20mA) will increase.

The sensor is set to give a proportional value of 4mA or 8mA with no flame in view. The value increments when flame flicker pulses are seen. With an output value approaching 20mA the fire LED will illuminate.

Values below 3.0mA are an indication of a fault condition. See Fig. 5

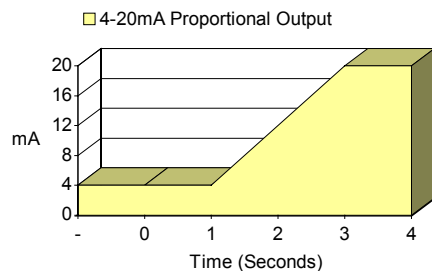

**Fig. 5** Typical Response on seeing Flame - IR Flame Sensor

Proportional output values between 4 or 8mA and 20mA can be used to provide an early warning of fire. These values hold only for 3 seconds from the last flame sighting. See Fig. 7

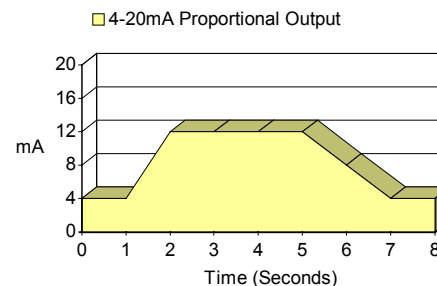

**Fig. 7** Typical Response to Burst of Flame - IR Flame Sensor